



STANDARD GAUGE DATA

CONSTRUCTION: ALUMINUM BODY ASTM B211-03
 OPERATION: DIAPHRAGM (BUNA CONVOLUTED)
 TEMPERATURE: 180°F / 80°C
 PRESSURE: 500 PSIG - 3450 KPA
 APPROX. WEIGHT: 3.75 LBS (1.7 KGS)
 DISPLAY: USGPM / LPM or USGPM / M3H

4" DIAL STANDARD - 6" DIAL AVAILABLE

OPTION:
 DIGITAL GAUGE W/
 4-20ma TRANSMITTER



STANDARD VENTURI DATA

MATERIALS: MACHINED 1026 CARBON STEEL
 ASTM A-106 - B/C HRS

FLANGES: 150# WELD NECK STANDARD BORE

VALVES: 1/4" BRASS BALL
 Rated @ 600 WOG
 Body: ASTM-B584
 Tail Piece: ASTM B16 C36600
 Ball: ASTM B16 C36600
 (HARD CHROME PLATED)

BRASS FITTING: ASTM B16 C36600
 Meets functional requirements of the
 SAE J530, SAE J531 and ASA.

ID TAG: Laser Engraved Aluminum

HOSES: Rubber Hoses Rate at 750 PSI WP

VENTURI PATENT #D764,630 S

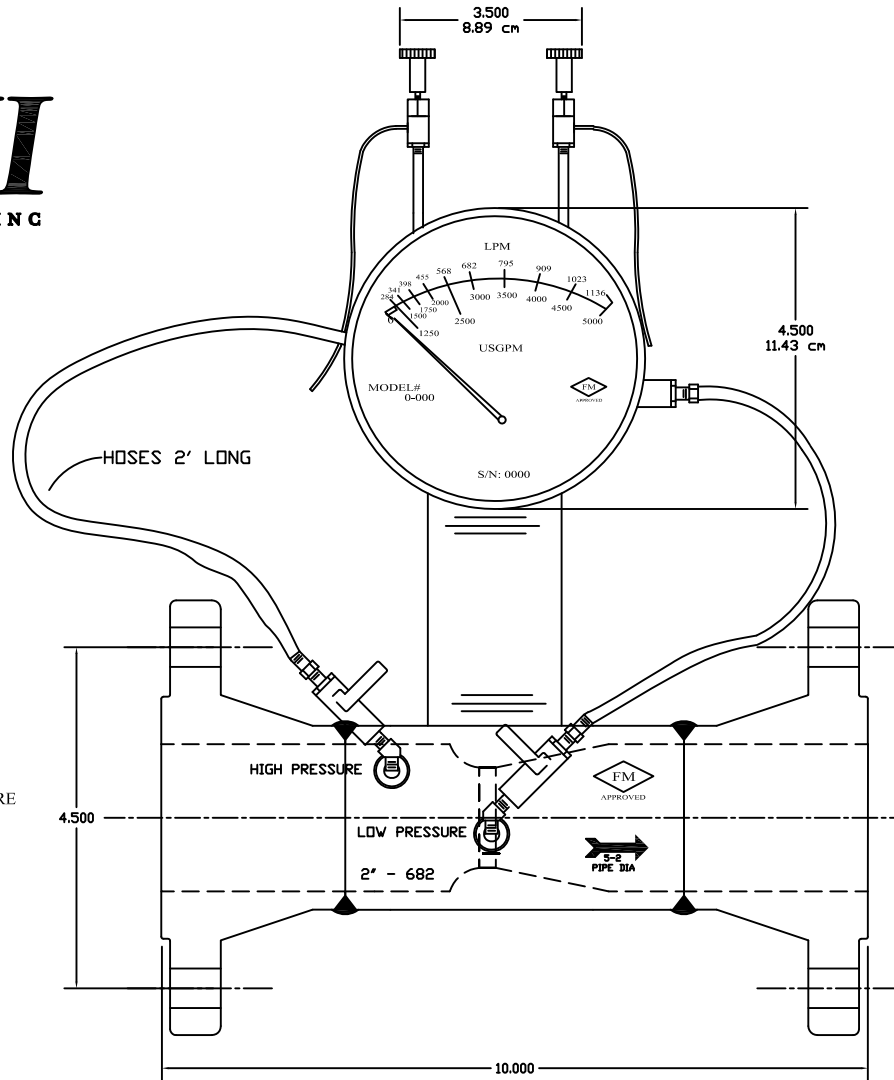

GVI 2" FLANGED 150#

GA DRAWING / SUBMITTAL DATA



TYPICAL INSTALLATION

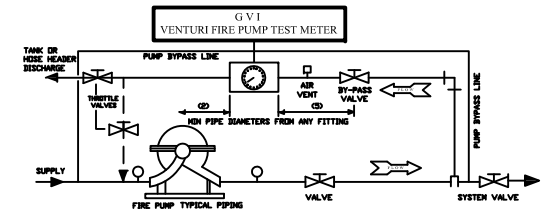

OPERATING INSTRUCTIONS

1. CLOSE SYSTEM VALVE.
2. OPEN SYSTEM BY-PASS VALVE AND THROTTLE VALVE.
3. PURGE METER LOCATED ON VENTURI AS FOLLOWS:
 - OPEN SHUT-OFF VALVES & VENT VALVES.
 - WHEN A STEADY STREAM OF WATER IS PASSING THROUGH EACH PLASTIC HOSE, THE METER IS PURGED OF AIR.
 - CLOSE VENT VALVE AFTER PURGING.
4. START FIRE PUMP, READ METER IN GPM / LPM
5. REFER TO PUMP GPM / LPM REQUIREMENT AND ADJUST THROTTLE VALVE FOR THIS REQUIREMENT.
6. AFTER TEST OPEN SYSTEM VALVE AND CLOSE SYSTEM BY-PASS AND THROTTLE VALVES.

CERTIFIED BY CHARLES P. SUTTON - PRESIDENT

GLOBAL VISION INC.

8730 JEFFERSON HWY
 OSSEO, MINNESOTA 55369
 763 - 391 - 0990

**FIRE PUMP ASSEMBLY
 2" FLANGED 150#**

DATE:	6/1/09
SCALE:	NTS
DWG #	FV2M-F
	FLANGED